

Separatore olio

RAMEF 2950 FR





Separatore olio RAMEF 2950 FR

Harchill acet. Les plautam cus sumquo de re nis es mi, con cus sum, testota soluptatur, solesto cusandit rendicilis vendandis pa voluptatem quodis ma autem venima sum fuga. Ferore, temporporem que excerovid et latibusda voloribust aut faccae illorume venit, cus mos sectotaecea volestest adipienis verrovit dolupta tianducit venducipsam labores. Ferore, temporporem.

Quodis ma autem venima sum fuga. Ferore, temporporem que excerovid et latibusda voloribust aut faccae illorume venit, cus mos sectotaecea volestest adipienis verrovit dolupta tianducit. Quodis ma autem venima sum fuga. Ferore, temporporem que excerovid et latibusda voloribust aut faccae illorume venit, cus mos sectotaecea volestest adipienis verrovit dolupta tianducit.

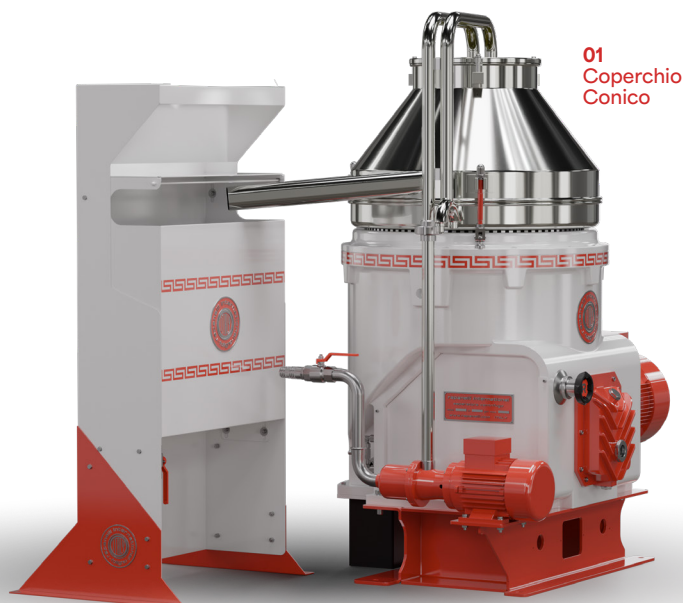

01
Coperchio
Conico

Specifiche tecniche

Motore principale	7,5 kW
Motore principale	6200 rpm
Motore pompa mosto	0,55 kW
Capacità produttiva	2200 - 2500 l/h
Tempo di avviamento	4 min
Temperatura di alimentazione max.	100°C
Livello di rumorosità max.	≤ 80 dB(A) EN ISO 4871
Peso	1000 kg

Dimensioni

AxBxH	1630x1280x1830 mm
-------	-------------------

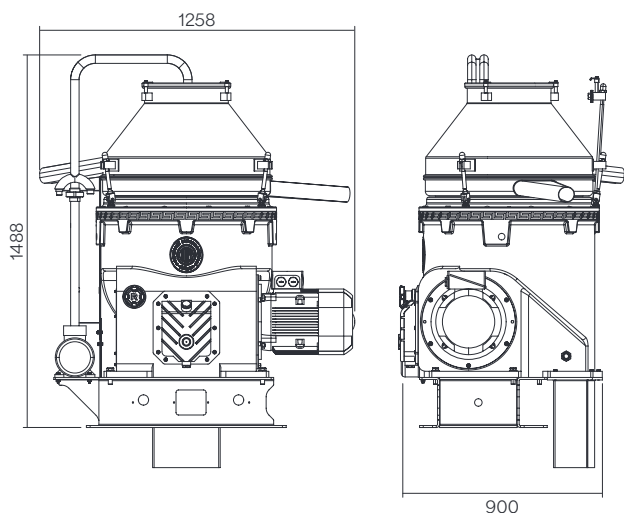

02
Coperchio
Cilindrico



Dati materiali

Copertura, tamburo	Acciaio inox Aisi 304
Basamento	Ghisa
Guarnizioni e O-ring	Gomma nitrilica

